

# CPTAU, PRE-INSULATED BIMETAL LUG

CPTAU pre-insulated bimetal lugs are used to establish connection between low voltage aerial cable and electrical equipments.

- Material: palm: Cu≥99.9%, barrel: Al≥99.5%
- Insulation sheath is made of weather and UV resistant material
- Clear markings on insulation sheath to indicate crimping die, crimping sequence and times, cross-section of conductor and stripping length.
- Cross-section of conductor can be easily identified by the color of elastomeric cap.
- Elastomeric cap and pre-filled silicone grease ensure superior waterproof.
- Stripping of cable insulation is required before insertion.
- Tested for watertightness test.
- Standard: EN 50483-4, NF C 33-021

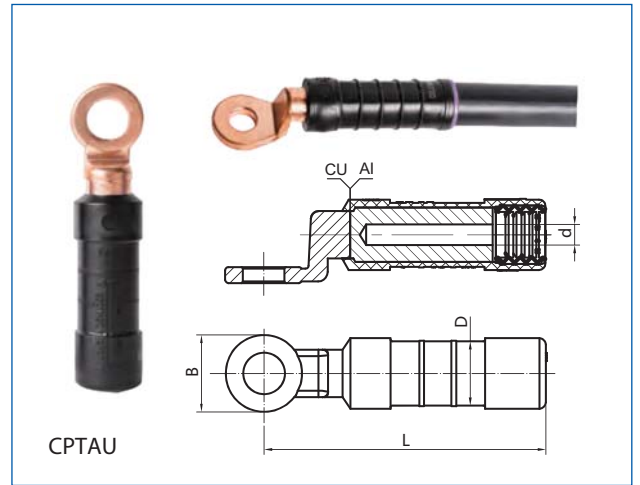

Type	Conductor Size (mm <sup>2</sup> )	Dimensions(mm)				Stud Size	Color Code	Pack (pcs)	Crimping Die
		L	d	D	B				
CPTAU16-10	16	65	5.3	16	20	M10	blue	120x4	E140
CPTAU25-12	25	88	6.5	20	24	M12	orange	60x4	E173
CPTAU35-12	35	88	7.9	20	24	M12	red	60x4	E173
CPTAU50-12	50	88	8.8	20	24	M12	yellow	60x4	E173
CPTAU54.6-12	54.6	88	10	20	24	M12	black	60x4	E173
CPTAU70-12	70	88	10.4	20	24	M12	white	60x4	E173
CPTAU95-12	95	88	12.3	20	24	M12	grey	60x4	E173
CPTAU120-12	120	102.5	14.2	25	30.5	M12	pink	40x4	E215
CPTAU150-12	150	102.5	15.5	25	30.5	M12	violet	40x4	E215